

# ST-400 / ST-600 STEREOCOM Installation Instructions

## INTRODUCTION

**ATTENTION INSTALLER:** To assure a trouble free installation, please read the entire instructions through once before beginning.

**CONFIGURATION** - Sigtronics Stereocom systems are specifically designed for permanent, panel mounted installation in aircraft. They are configured in two sections: a SPA-400 (4 place) or SPA-600 (6 place) intercom with transmit capability, and a RES-401 or RES-601 Stereo Music Switcher. Both intercom and switcher may be installed at the same time, or the switcher section may be easily added to an existing SPA intercom installation.

**MUSIC INPUTS** - The Stereocom music inputs are fully compatible with music systems that have line level output, headphone level (Walkman) output, or speaker output up to 25 watts per channel. No amplifiers, adapters or modifications to the RES unit are required.

**SIZE SPA UNIT** - Panel 1" x 2.5". Chassis - 1" high x 2.5" wide x 6" deep. Can be mounted either horizontally or vertically in the aircraft panel.

**SIZE RES UNIT** - A 4" x 2.9" x 2" chassis mounted remotely.

**WEIGHT SPA UNIT** - 4.5 ounces (SPA-400 intercom unit with panel and knobs). Jacks and wiring harness weigh 5.5 ounces.

**RES UNIT:** 9.8 oz. (RES-401). Harnesses - 5.2 oz.

**INPUT POWER** - 11VDC through 32VDC. Maximum current drain 0.13 Amp (ST-400).

**DISTORTION** - Less than 1% total harmonic distortion.

**ENVIRONMENTAL** - Meets requirements of TSO-C50b.

**WARRANTY** - The ST units are constructed of high quality components and carry a five year parts and labor warranty.

## INSTALLATION FOR COMPLETE ST-400 / ST-600 SYSTEM

If a RES-401 or RES-601 is to be added to an existing SPA installation, proceed to the "Installation Retrofit" on page 3.

## Hardware Supplied

Besides the intercom and music switcher unit, each Stereocom system comes with the following hardware:

	ST-400	ST-600
Headphone Output Jacks - Accept standard 0.250" aircraft stereo headphone plugs.	4	6
Microphone Input Jacks - Accept standard 0.206" aircraft microphone plugs. (U93 plug compatible jacks can be used in place of the jacks provided - mono installations only).	4	6
Mic Jack Insulating Washers, Flat	4	6
Mic Jack Insulating Washers, Shoulder	4	6
SPA Panel - lettered on both sides for horizontal or vertical mounting.	1	1
Intercom/Aircraft Interface Cable (4 feet long)	1	1
Intercom Control Knobs	2	2
Switch Nuts	3	3
SPA Mounting Screws 4-40 x 1/2	2	2
SPA Drill Template - Adhesive backed hole size pattern for drilling aircraft panel.	1	1
Music Input / Interface Cable (4 feet long)	1	1
Music Switch Harness (4 feet long)	1	1
Music Switch Panel	1	1
Stereo Music Input Jack - 3.5mm	1	1
RES Mounting Screws	4	4
RES Mounting Nuts	4	4

## SPA-400 / 600 CHASSIS INSTALLATION

The location selected requires a minimum front panel area of 2 1/2" by 1". Depth required behind panel is 4" plus cable access. Allow approximately 1" by 1 1/2" space nearby to mount the music switch panel.

**CAUTION:** Move aircraft flight controls through limits of travel while observing selected area to make certain intercom components will not interfere with aircraft control components.



**Specialists in "SOUND" Management**

178 East Arrow Highway, San Dimas, CA 91773 ( 909 ) 305-9399

## Panel Preparation:

1. Position the adhesive drill template on the aircraft panel in the selected area.
2. Center punch each hole at cross lines. (The five holes are in a straight line and equally spaced 0.4" apart.)
3. Drill a 1/8" pilot hole in all five places.
4. Enlarge one hole to 1/2" and two holes to 3/8" per template.

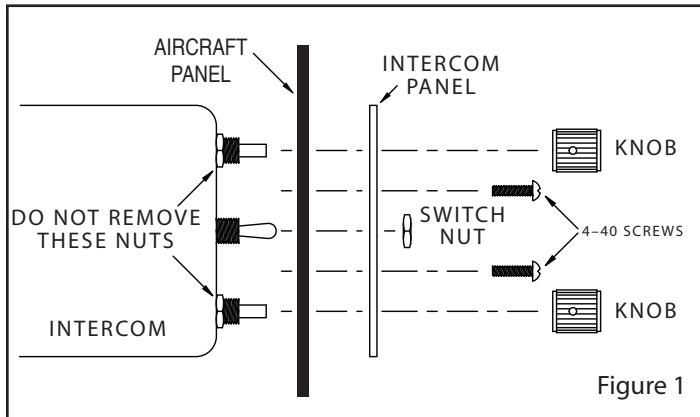

Figure 1

## Mounting Chassis: See Figure 1

1. Remove the nut from the SPA ON/OFF switch bushing.
2. Remove the knobs from the VOLume and SQuelch controls using a 0.050 inch Allen wrench. NOTE: DO NOT REMOVE nuts from the VOLume and SQuelch control potentiometers.
3. Insert the SPA unit from rear of the aircraft panel with the appropriate arrow on the unit chassis pointing upwards.
4. Install the panel and lightly thread the nut on to the ON/OFF switch. The nuts on the VOLume and SQuelch controls should fit inside the 3/8" diameter holes drilled in aircraft panel.
5. Install and tighten the two 4-40 screws through holes in SPA panel. Tighten the ON/OFF switch nut.
6. Install the knobs on the VOLume and SQuelch control shafts and tighten the Allen screws.

## RES-401 / 601 SWITCHER CHASSIS INSTALLATION

1. As in mounting the intercom, select a mounting location that will not cause interference with flight controls. Mount the RES Switcher unit within 3 feet of the SPA intercom to allow connection of J1 and P1.
2. Remove the four corner (smaller) panel screws and remove the RES unit from its chassis box.

3. Drill four mounting holes in the aircraft with same hole pattern as in the switcher chassis. Use a #27 drill. (Clearance drill for 6-32")
4. Secure the chassis to the aircraft with the four 6-32 screws and nuts provided. The screw heads should be inside switcher chassis for circuit board clearance. Care should be taken not to crush grommets while applying torque to screws.
5. Replace the RES unit in the chassis box and secure.

## SWITCHER HARNESS INSTALLATION

1. Using the Music Switch Panel for a guide, select an area on the aircraft panel and drill 1/4" diameter holes for the MUSIC ON/OFF and PILOT/ALL Switches.
2. Mount the switches with the bushing key slots down. The smaller switch (MUSIC ON/OFF) mounts on the right.
3. Place the printed switcher panel over the switch bushings and install and tighten the two switch nuts.
4. Route the cable harness to the Switcher unit clear of aircraft controls. Secure with suitable wire ties.

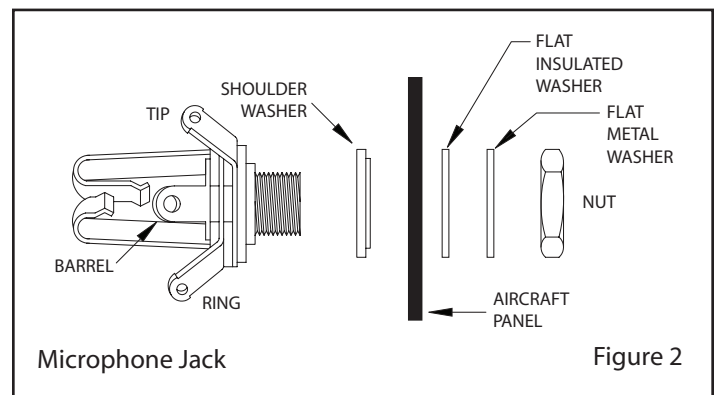
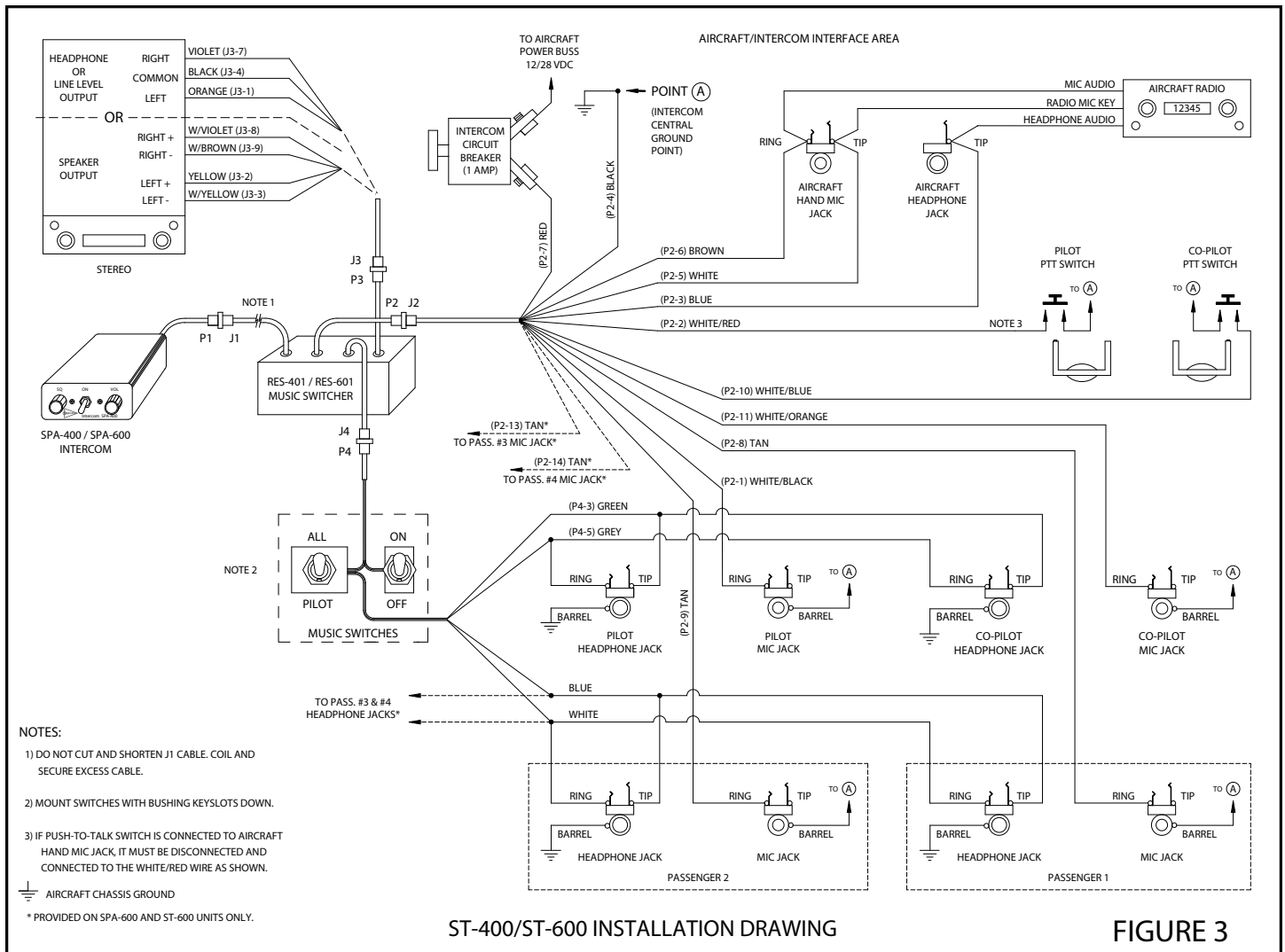

Figure 2

## MOUNTING HEADPHONE AND MICROPHONE JACKS

1. Locate the mounting areas. One mic and one headphone jack required for each headset.
2. Drill 3/8" diameter holes for headphone jacks and install. The terminals on the stereo phone jacks may be identified per the mic jack shown in Figure 2 above. The phone jack bushings (sleeve terminal) must be grounded to airframe or wired to aircraft ground.
3. Drill 1/2" diameter holes for mic jacks and install with insulating washers supplied. See Figure 2.

Note: If the aircraft already has headset jacks (not including the hand mic jack), they can be used for this system, however, any existing wires must be removed and the jacks must be wired as shown in Figure 3 on page 3. Additionally, if any existing mic jack is mounted in metal, insulating washers must be installed and the barrel connection wired back to Point "A".



J2 PIN	WIRE COLOR	FUNCTION	CONNECT TO:
1	White / Black	Pilot Mic Input	Ring Terminal of Pilot Mic Jack
2	White / Red * 8	Pilot Transmit Switch Input	Pilot Transmit Switch (PTT). Switch to Ground to Transmit.
3	Blue * 3	Radio Headphone Input	Radio Headphone Output
4	Black * 4	Intercom Ground	Aircraft Chassis Ground – Central Grounding Point “A”
5	White * 8	Radio Transmit Key Output	Radio or Audio Panel Transmit Key Input
6	Brown	Transmit Mic Audio Output	Ring Terminal of Hand Mic Jack or Mic Input of Radio or Audio Panel
7	Red * 5	Power Input (12 through 28 VDC)	Intercom Circuit Breaker
8	Tan * 6	Passenger #1 Mic Input	Ring Terminal of Passenger #1 Mic Jack
9	Tan * 6	Passenger #2 Mic Input	Ring Terminal of Passenger #2 Mic Jack
10	White / Blue * 8	Co-Pilot Transmit Switch Input	Co-Pilot Transmit Switch (PTT)
11	White / Orange	Co-Pilot Mic Input	Ring Terminal of Co-Pilot Mic Jack
12	—	—	—
13	Tan * 6	Passenger #3 Mic Input	Ring Terminal of Passenger #3 Mic Jack
14	Tan * 6	Passenger #4 Mic Input	Ring Terminal of Passenger #4 Mic Jack
15	—	—	—

**TABLE 1** \* See corresponding number paragraphs under the “WIRING INSTRUCTIONS” section starting on page 4.

## WIRING INSTRUCTIONS

1. Connections should be made as shown in Figure 3 and Table 1 on page 3.
2. If longer wire lengths are required, use a good quality multi strand hook-up wire - 22 gauge or larger. Although not necessary, shielded audio wire can be used if desired. This can simplify the wiring process.
3. The blue wire from J2 Pin 3 must be connected to the aircraft radio headphone output - NOT the speaker output.
4. Connect all intercom mic jack grounds to a single aircraft chassis ground point - Point "A" - as shown in Figure 3. Use the black washers supplied to insulate the intercom mic jacks from aircraft chassis ground. NOTE: this intercom central grounding point is used to eliminate any unwanted electrical noises, such as alternator whine or strobe noise, from being induced into the intercom system through the grounds. All intercom mic jack barrels must be insulated from ground where they are mounted and connected back to Point "A" on their own individual ground wire. Similarly, both intercom ground wires (J2 pin 4) and the push-to-talk switch grounds must also be connected back to Point "A". It is not necessary, however, to connect the headphone jack barrels to Point "A". They can either be grounded where they are mounted or some place nearby.
5. The red wire may be connected to either 12V (14V) or 24V (28V) power source. No switching or adjustments are required to operate from either source.
6. Tan wires (J2 pins 8, 9, 13, and 14) are only used on installations that require extra intercom positions. Tan wires pins 13 and 14 are provided on ST-600 units only.
7. Do not cut and shorten J1 cable. Coil and secure any excess cable.
8. If the aircraft has existing push-to-talk switches they must be disconnected from wherever they are currently and connected exactly as shown in Figure 3.
9. The wires used in the stereo music input cable (J3) depends on the type of stereo used. Use the White/Violet, White/Brown, Yellow, and White/Yellow wires for stereos with speaker outputs (25 watts per channel maximum). Use the Violet, Black, and Orange wires for a Line Level or Headphone Level (Walkman) output. A small stereo panel mount music jack is provided for portable stereo input, if desired. Connect the Violet, Black, and Orange wires to the jacks terminals as shown in Figure 4 on this page. Drill a 1/4 inch hole and mount the jack on the aircraft panel. To use, connect an adapter cable between the music input jack and the output of the portable stereo. Suitable cables are available at your local Stereo or electronics store as well as from Sigtronics.

10. A Sigtronics Stereo-com system can be installed for use with monaural general aviation type headsets. Follow the installation instructions as normal except for the wiring of the stereo headphone jacks. Use the stereo headphone jacks supplied with the Sigtronics Stereo Switcher but leave the "RING" connections open. Connect both headphone wires to the "TIP" of the respective jacks - P4 cable GRAY and GREEN for the pilot and co-pilot, and BLUE and WHITE for passengers. See Figure 3 on page 3.

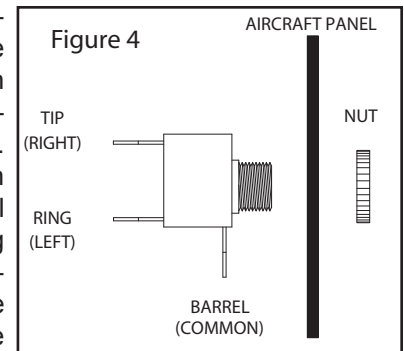

11. Make sure any unused wires are properly insulated and kept from shorting to any other wires or aircraft ground.

Skip down to the "INSTALLATION CHECK OUT AND ADJUSTMENT" section on page 5.

## INSTALLATION RETROFIT

Follow these instructions if the RES switcher is to be added to a previously installed SPA-400 or SPA-600:

1. Mount the RES switcher chassis per the "RES-401 / 601 SWITCHER CHASSIS INSTALLATION" instructions on page 2.
2. Install the MUSIC ON/OFF and PILOT/ALL Switches and route the harness per the "SWITCHER HARNESS INSTALLATION" instructions on page 2.
3. Unplug the SPA unit from its wiring harness and insert connectors J1 and P2 on the RES unit as shown in Figure 3.
3. Connect remaining plugs per Figure 3 on page 3.
4. Remove the intercom headphone jacks from the pilot, co-pilot, and passenger positions in aircraft. Wires, which had been connected to the phone jacks should be cut, insulated and tied back. If two or more wires appear on a single jack terminal, they should be cut free of the jack, then spliced together before insulating and tying back. Do not disturb the microphone jacks.
5. Replace headphone jacks with three-terminal type "stereo" jacks supplied with the RES switcher. Connect wires to the stereo jacks per Figure 3. Terminals on the stereo phone jacks may be identified per the mic jack shown in Figure 2 on page 2. The jack bushings (barrel terminal) must be grounded to the airframe or wired to aircraft ground. For monaural operation See Note 10 above in the "WIRING INSTRUCTIONS" section.
6. Connect up stereo music source per Figure 3 and Notes 9 and 11 above.

## INSTALLATION CHECK-OUT AND ADJUSTMENTS

After the system is installed, again check that the SPA and RES unit chassis, jacks, and wiring harnesses are clear of all aircraft operating controls and cause no interference with them. Check out the Stereocom installation by following the instructions:

Plug in all the headset mic and phone plugs into the respective intercom jacks. Put on the pilot's headset and position the boom mic close to the mouth, as is the practice with a hand-held mic. Voice clarity is best when the mic is at one side of the mouth and 1/4" from the lips.

To assure that the aircraft radios, pilot's headset, and PTT switch are connected and functioning properly, turn the SPA units ON/OFF switch to the "OFF" position. Turn the MUSIC ON/OFF switch to "OFF" and the PILOT/ALL switch to "ALL". If applicable, set the aircraft audio panel to "Headphone" position. Then turn on the aircraft radio(s) as usual, and verify that the pilot can hear the radios and can transmit using his push-to-talk switch and headset. Aircraft radio(s) and audio panel should operate exactly as they did before the Stereocom system was installed. Aircraft radio reception should be heard in all headsets. There should be no intercom between headsets with the SPA unit turned "OFF".

Next turn the SPA unit ON/OFF switch "ON". Set the SPA volume control to mid-position. For now, turn the SPA Squelch control full clockwise. Verify that all headset positions can now intercom with each other, including the passengers. Verify that both pilot and co-pilot can operate the aircraft radio(s). In this mode all headsets on the intercom will hear the aircraft radio(s).

It may be necessary at this time to adjust the SPA unit transmit mic output to the aircraft radios. A small adjustable potentiometer is provided inside the unit for this purpose. It is accessible through a hole in the side of the SPA chassis. It is marked "MOD. ADJ.", and can be adjusted with a small blade screw-driver. In the event of over modulation (garbled) or reports of weak transmission's over the aircraft radio, an appropriate adjustment can be made. Clockwise rotation increases the output level to the aircraft radio mic input. Counter-clockwise rotation decreases modulation level. This adjustment sometimes needs to be made after the initial installation of the intercom or if a new radio is installed. (The output is set for unity gain at Sigtronics)

Mode Selection Table			
PILOT/ ALL SWITCH	MUSIC SWITCH	PILOT & CO-PILOT HEAR	PASSENGERS HEAR
All	Off	VHF and ICS	VHF and ICS
All	On	Music interrupted by VHF & ICS	Music interrupted by VHF & ICS
Pilot	Off	VHF and ICS	Music Only
Pilot	On	Music interrupted by VHF & ICS	Music Only
VHF – Aircraft VHF Radio		ICS – Intercom Audio	

To verify music operation, connect your music source to the music input jack, if applicable. Turn on the music

source and set volume to low level. Next turn "ON" the Stereocom MUSIC ON/OFF switch. When the aircraft radio and intercom are quiet you will hear music in the headsets. Adjust the music source volume to a comfortable level. Verify that music is heard in all headsets and is interrupted by intercom conversations. If everything checks out, refer to the separate ST-400 / ST-600 STEREOCOM OPERATING INSTRUCTIONS sheet for proper use and other operating modes of the Sigtronics Stereocom system. If something does not work as described, carefully go over the system wiring again. If OK, refer to the following section for helpful hints and solutions to common problems:

### HELPFUL HINTS AND TECHNICAL INFORMATION

#### SPA-400 / SPA-600 Sidetone Modification

Most aircraft radios, when transmitting, provide what is called "sidetone". Without sidetone, you will not hear yourself or your co-pilot transmit to ATC. This can be distracting, especially during instruction, because no one on the intercom will hear the outgoing transmission of the radio conversation. Some aircraft radios, however, do not provide this function. Also, some radios are designed to drive only one headset. Therefore, if you have such a radio, the sidetone may be extremely weak or non-existent.

If this is the case and the sidetone cannot be turned up in the radio(s), a simple modification can be performed within the SPA unit to simulate sidetone. The SPA requires partial disassembly to accomplish this modification. First unplug and remove the SPA unit from the aircraft. To disassemble unit, carefully remove the three screws securing the bottom cover. Remove the cover to expose the solder side of the circuit board.

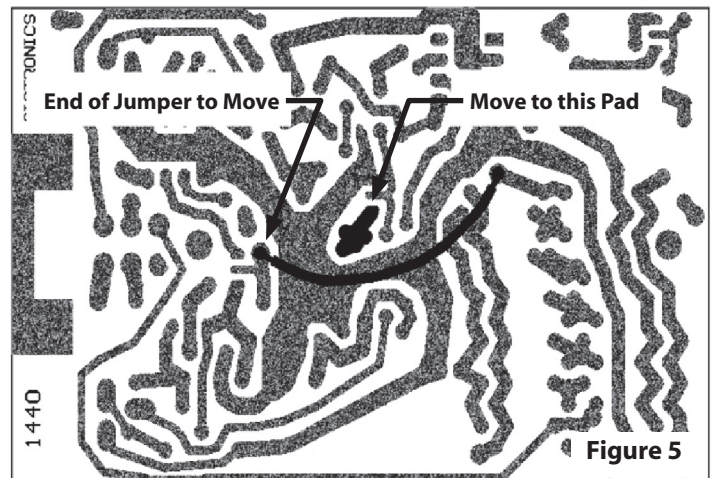

Unsolder the wire from the solder trace at the end closest to the controls. Move the free end of the wire to the solder pad as illustrated in Figure 5 and solder. Replace the cover and the three screws to complete the modification. Install the SPA unit into the aircraft panel and plug in the cable.

With the unit modified in this way, the intercom VOLume control adjusts the level of the sidetone. Note, when "OFF" the SPA unit will not provide sidetone even with this modification.

## SPA-400 / SPA-600 ICS Load Modification

This modification is used when a SPA intercom is connected to a radio or audio panel that has a low impedance headphone output (less than 100 ohms). This is most common with some Narco equipment (CP-135, CP-136, and Mark 12D, for example) and "home made" audio select panels. Symptoms are:

1. Intercom audio volume is weak or non-existent when the SPA unit is in "ON" and ...
2. Transmit function is normal on aircraft radio and ...
3. Receive function is normal on aircraft radio.

Solution: Add a 1/4 or 1/2 watt resistor in-line with the BLUE wire from pin 3 of J2. The value of the resistor most commonly used is 220 ohms. However, optimum performance can be achieved by selecting the value right for your particular installation. The resistor can be any value between 100 and 330 ohms and is selected for the best balance between radio receive volume and intercom volume.

## Stereo Music Systems

Most automotive stereo units operate from 12V-14V sources. Regulators or converters are available to permit operation from 24V-28V sources.

Some FM receivers are capable of causing interference with aircraft COM and NAV receivers. The aircraft panel should be placarded accordingly. Most player only units (cassette or CD) do not cause interference with aircraft receivers.

## Stereo Headsets

The Sigtronics Stereocom systems are designed for use with general aviation Stereo headsets with high impedance speakers (300 to 600 ohms). Headsets with low impedance (less than 100 ohms) speakers cannot be used with Stereocom systems without modification. Contact Sigtronics for details. In general, headsets with speakers of high and low impedance and/or unmatched audio efficiencies should not be used together without modifications.

Sigtronics manufactures stereo headsets specifically designed for aircraft high noise environments and give excellent noise attenuation. They also provide full frequency response stereo for maximum enjoyment. They are compatible with aircraft mic circuits and can be used as general aviation headsets in aircraft that are not equipped with stereo headphone jacks. This is because they include a switch to change from "Stereo" to "Monaural". No adapters required.

NOTE: General aviation headset (monaural) phone plugs should not be plugged into Stereocom stereo phone jacks. A monaural plug in a stereo jack shorts out one of the audio channels and therefore renders the aircraft VHF radio and intercom reception inoperative. (You may still here music, however.) General aviation headsets may be used only if one of the following three changes are made:

1. Monaural to stereo adapters are used on the headset headphone plugs. (Only monaural music will be heard.)
2. The general aviation headsets are re-wired for stereo reception.
3. Install the Sigtronics Stereocom system for monaural operation. See note 10 on page 4 in the "WIRING INSTRUCTIONS" section.

If something is still not right or you have any questions regarding the installation and operation of the Sigtronics Stereocom system or any other Sigtronics product feel free to contact us directly. Technicians are available Monday through Friday 8 am to 4:30 pm Pacific time.

This concludes the installation check-out. See the separate ST-400 / ST-600 STEREOCOM OPERATING INSTRUCTIONS sheet for complete Stereocom operation information.

## Sigtronics Corporation

178 East Arrow Highway  
San Dimas, CA 91773  
Phone: (909) 305-9399  
E-mail: info@sigtronics.com  
Web Site: www.sigtronics.com

