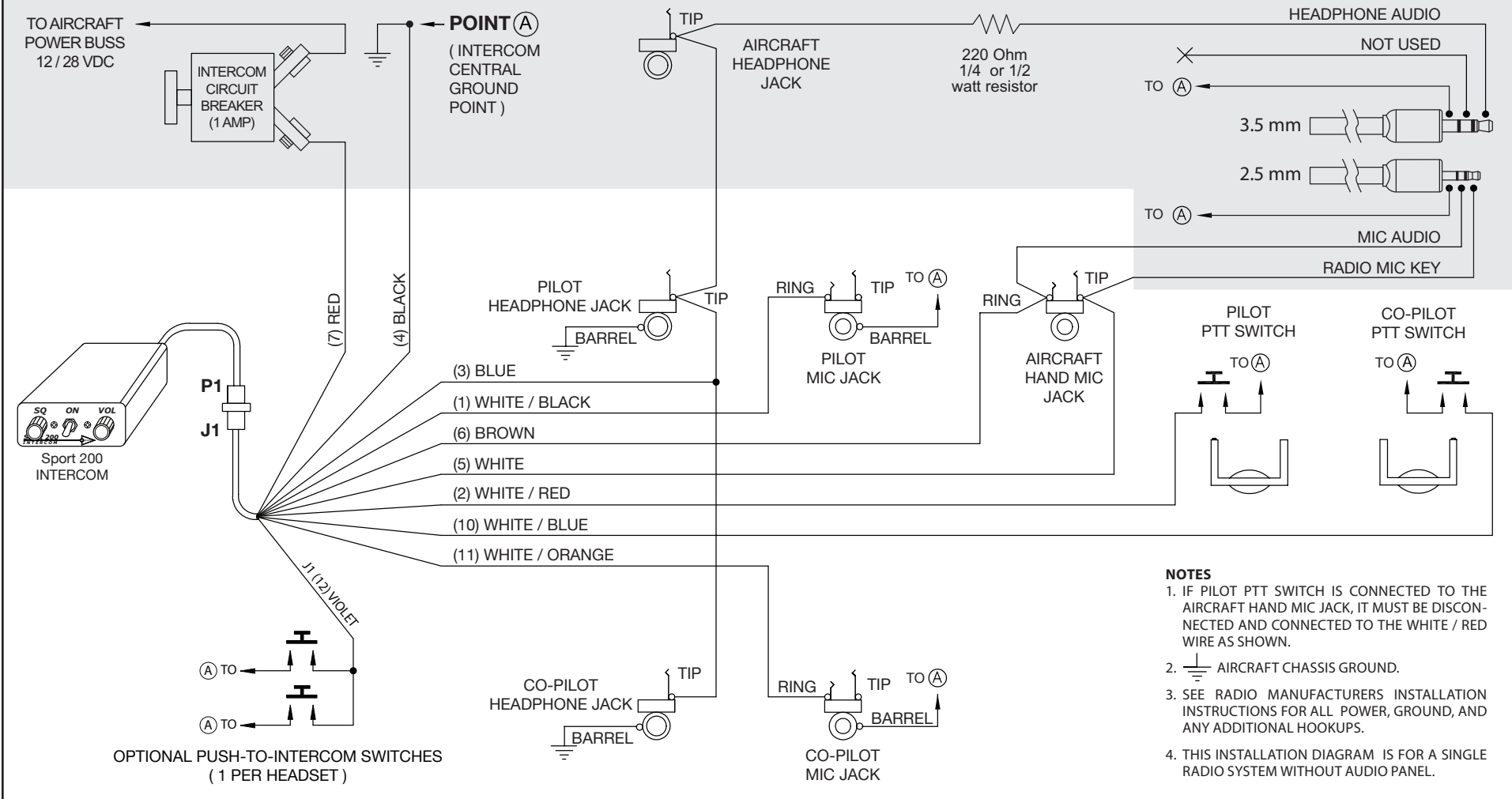

**Figure 4**

AIRCRAFT / INTERCOM INTERFACE AREA



- NOTES**
1. IF PILOT PTT SWITCH IS CONNECTED TO THE AIRCRAFT HAND MIC JACK, IT MUST BE DISCONNECTED AND CONNECTED TO THE WHITE / RED WIRE AS SHOWN.
  2. AIRCRAFT CHASSIS GROUND.
  3. SEE RADIO MANUFACTURERS INSTALLATION INSTRUCTIONS FOR ALL POWER, GROUND, AND ANY ADDITIONAL HOOKUPS.
  4. THIS INSTALLATION DIAGRAM IS FOR A SINGLE RADIO SYSTEM WITHOUT AUDIO PANEL.

**Sport 200 – ICOM A3, A6, A22, A24 Radio Installation Wiring Diagram**

