

G2-0049			
REV	OCN #	DATE	APR
A	010257	09 OCT 01	LBG
B	011089	14 DEC 01	TDS
C	012500	08 APR 02	TDS
D	016607	07 MAR 03	BJF
E	018686	18 JUL 03	ELF

NOTES:

1. SWITCHES TO BE INDIVIDUALLY BAGGED.
2. HARDWARE TO BE PLACED IN PLASTIC BAG.
3. SWITCHES, HARDWARE, HANDLE AND MANUAL TO BE PLACED INTO PLASTIC OVERPACK BAG, AND BOXED.
4. PROTECTIVE SHIPPING MATERIAL TO BE USED AS REQUIRED.
5. PLACE LABEL ON OUTSIDE OF BOX.
6. HANDLE MATERIAL IS GLASS REINFORCED POLYPROPYLENE.

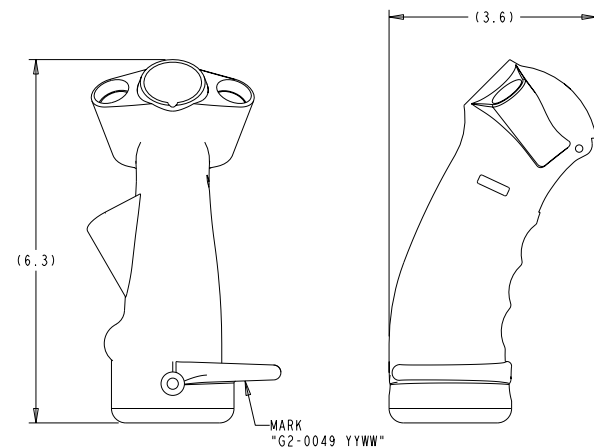
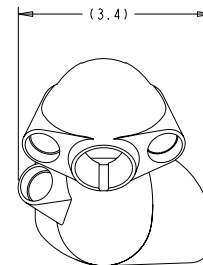
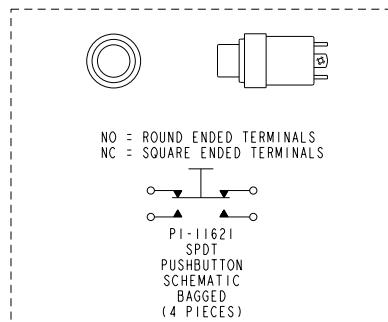
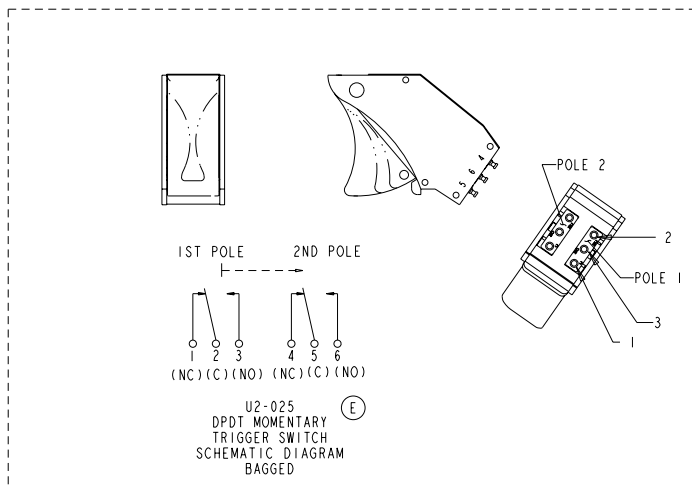
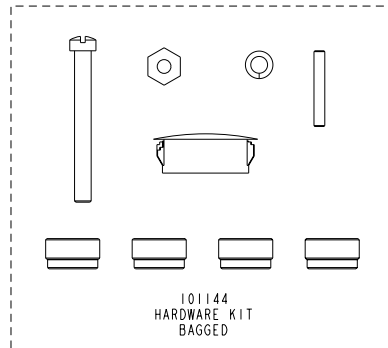
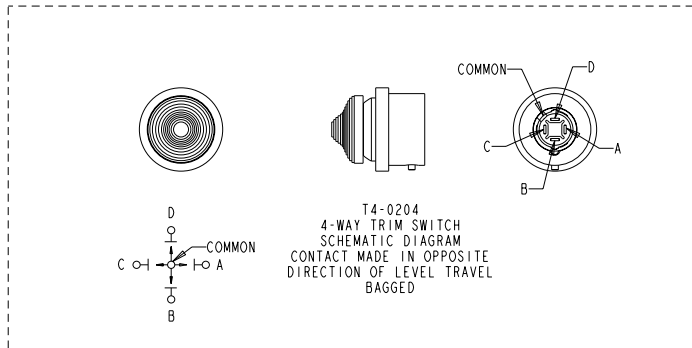

SPECIFICATION CONTROLLED DRAWING
This item is Customer/ATP Controlled.
No changes to this document or details
are permitted W/O customer authorization.

<p>UNLESS OTHERWISE SPECIFIED: DIMENSIONS ARE IN INCHES. TOLERANCES: .XX ±.03 .XXX ±.010 ANGLES ±7° DO NOT SCALE</p> <p>THIRD ANGLE PROJECTION</p>	<p>OTTO CONTROLS DIVISION OF OTTO ENGINEERING INC. CARPENTERSVILLE, ILLINOIS USA</p>		<p>DESCRIPTION G2, COBRA GRIP KIT</p>		
	<p>THIS DOCUMENT IS THE CONFIDENTIAL PROPERTY OF OTTO ENGINEERING, INC. IT IS PROVIDED ON A RESTRICTED BASIS AND IS NOT TO BE USED IN ANY WAY DETRIMENTAL TO THE INTERESTS OF OTTO ENGINEERING, INC.</p>	<p>DRWN. LBG CHKD. LBG APPD. JT</p>	<p>SIZE B</p>	<p>FSCM NO 21649</p>	<p>DRAWING NO. G2-0049</p>
<p>MANUFACTURING SPC</p>	<p>DATE 09-Oct-01</p>	<p>WT.</p>	<p>DO NOT SCALE Sheet 1 OF 1</p>		